

8 7 6 5 4 3 2 1

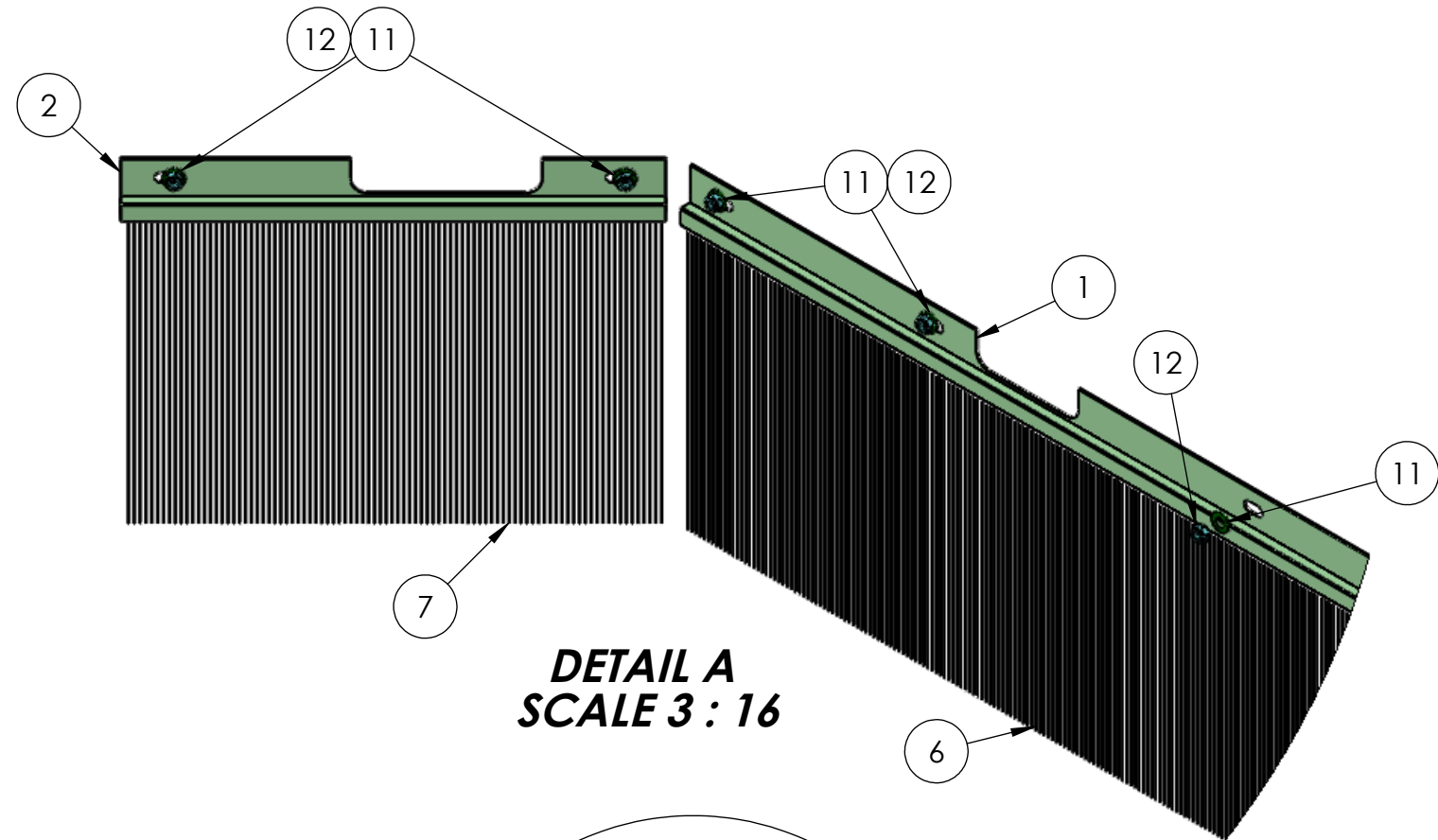

DETAIL A
SCALE 3 : 16

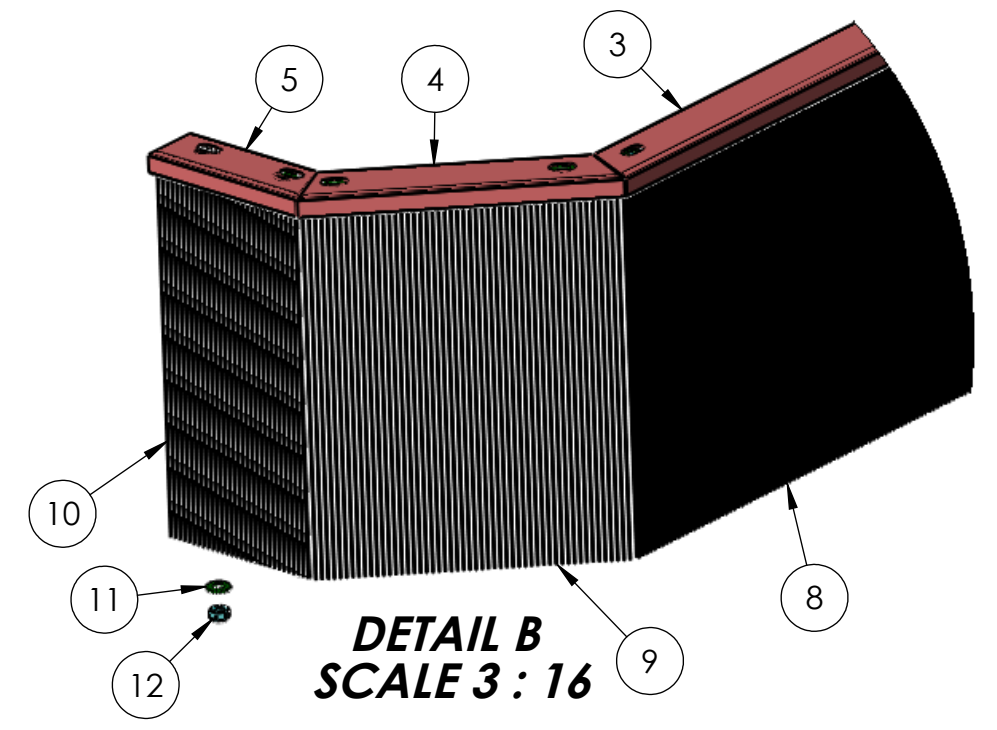

DETAIL B
SCALE 3 : 16

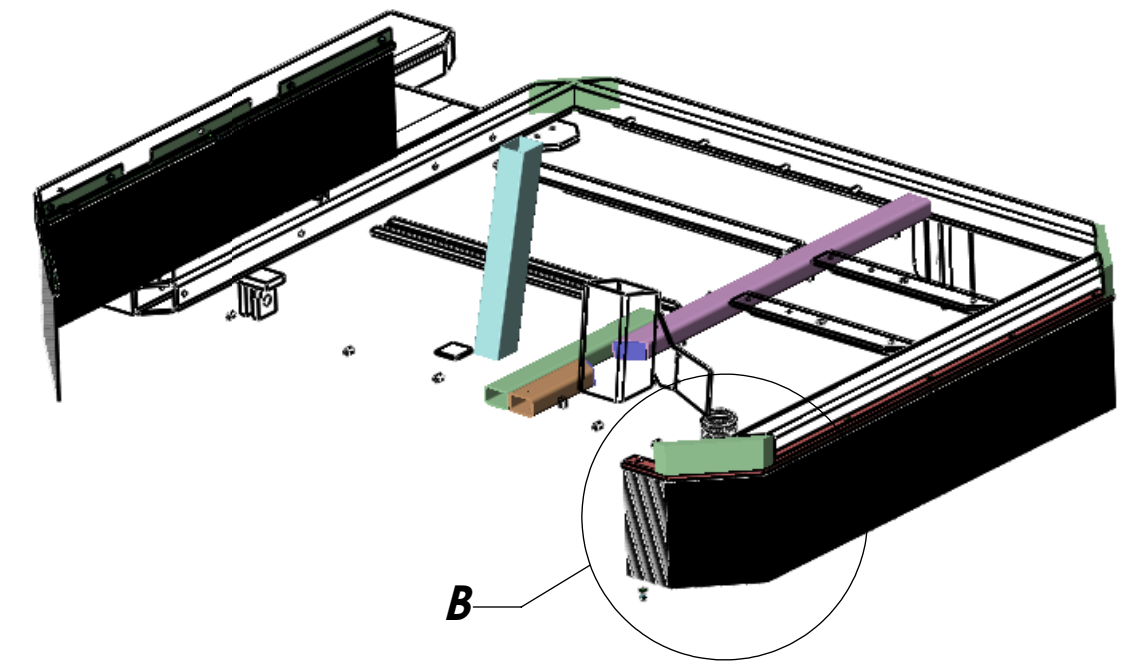
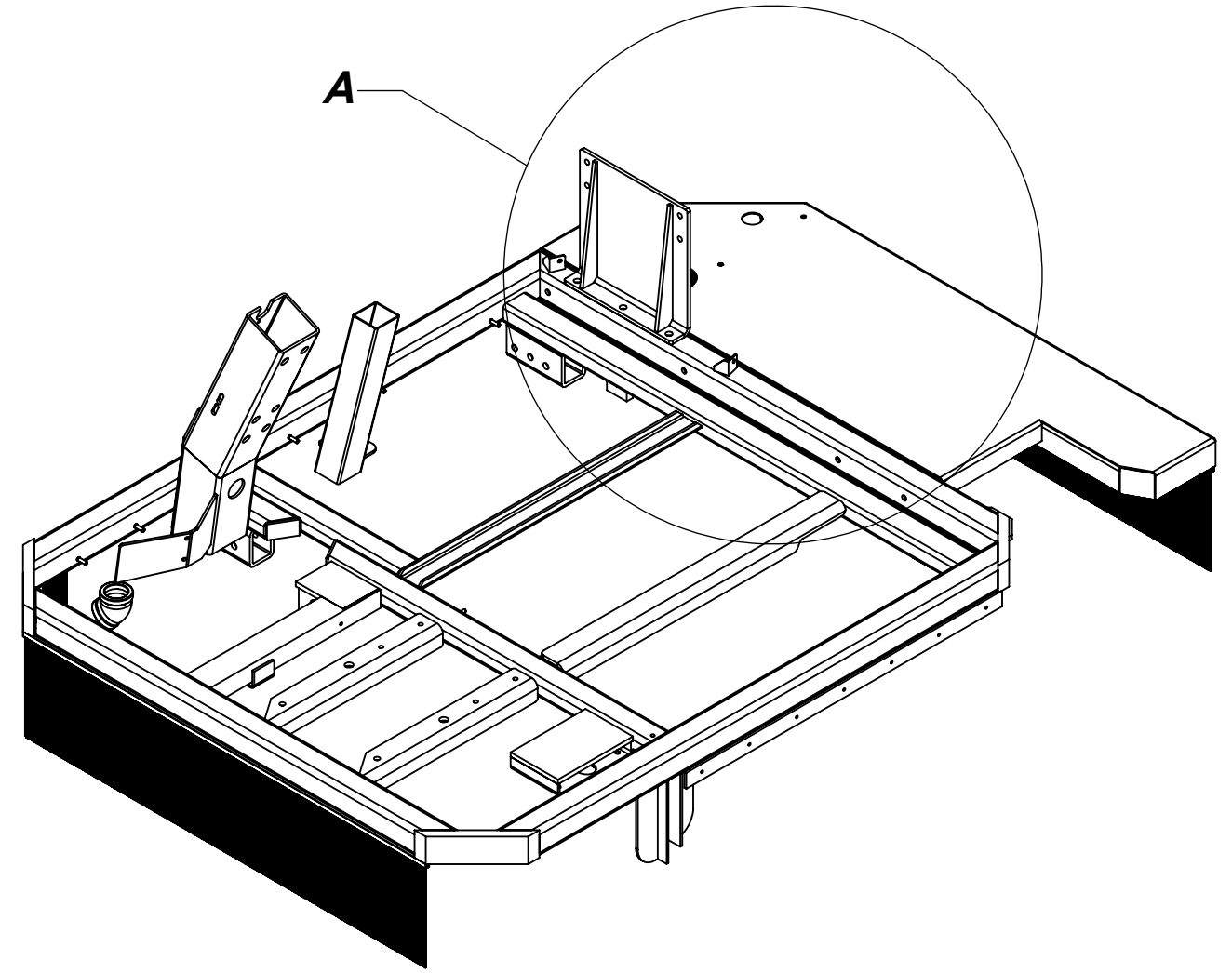

DIMENSIONS ARE IN INCHES TOLERANCES: DECIMAL: X.X ± 0.06 X.XX ± 0.03 X.XXX ± 0.005 ANGULAR: ± 0.5° FRACTIONAL ± 1/32"	DRAWN RWC	NAME RWC	DATE 11/26/12	TICO/TERMINAL SERVICE 66 CYPRESS RIDGE DR. RIDGELAND, SC 29936 (843) 717-2226	
	CHECKED	APPROVED	TITLE: SPRAY SUPPRESSION KIT		
	DO NOT SCALE DRAWING				SIZE B
	INTERPRET GEOMETRIC TOLERANCING PER: ASME 14.5M-1994	THE SUBJECT MATTER SHOWN AND DESCRIBED IN THIS DRAWING AND ANY OTHER INFORMATION ADVANCED IN CONNECTION THEREWITH, IS PROPRIETARY PROPERTY AND IS TO BE HELD IN STRICT CONFIDENCE BY YOU. ALL RIGHTS TO ANY INVENTIONS, DESIGNS, TRADE MARKS, TRADE NAMES AND COPYRIGHTS DISCLOSED ARE RESERVED TO TICO TERMINAL SERVICES, INC.			DWG. NO. 71622-D1
MATERIAL	FINISH	THICKNESS	REV D1	SCALE: 1:16	
				SHEET 1 OF 1	

8 7 6 5 4 3 2 1

