

**DETAIL D
SCALE 1 : 5**

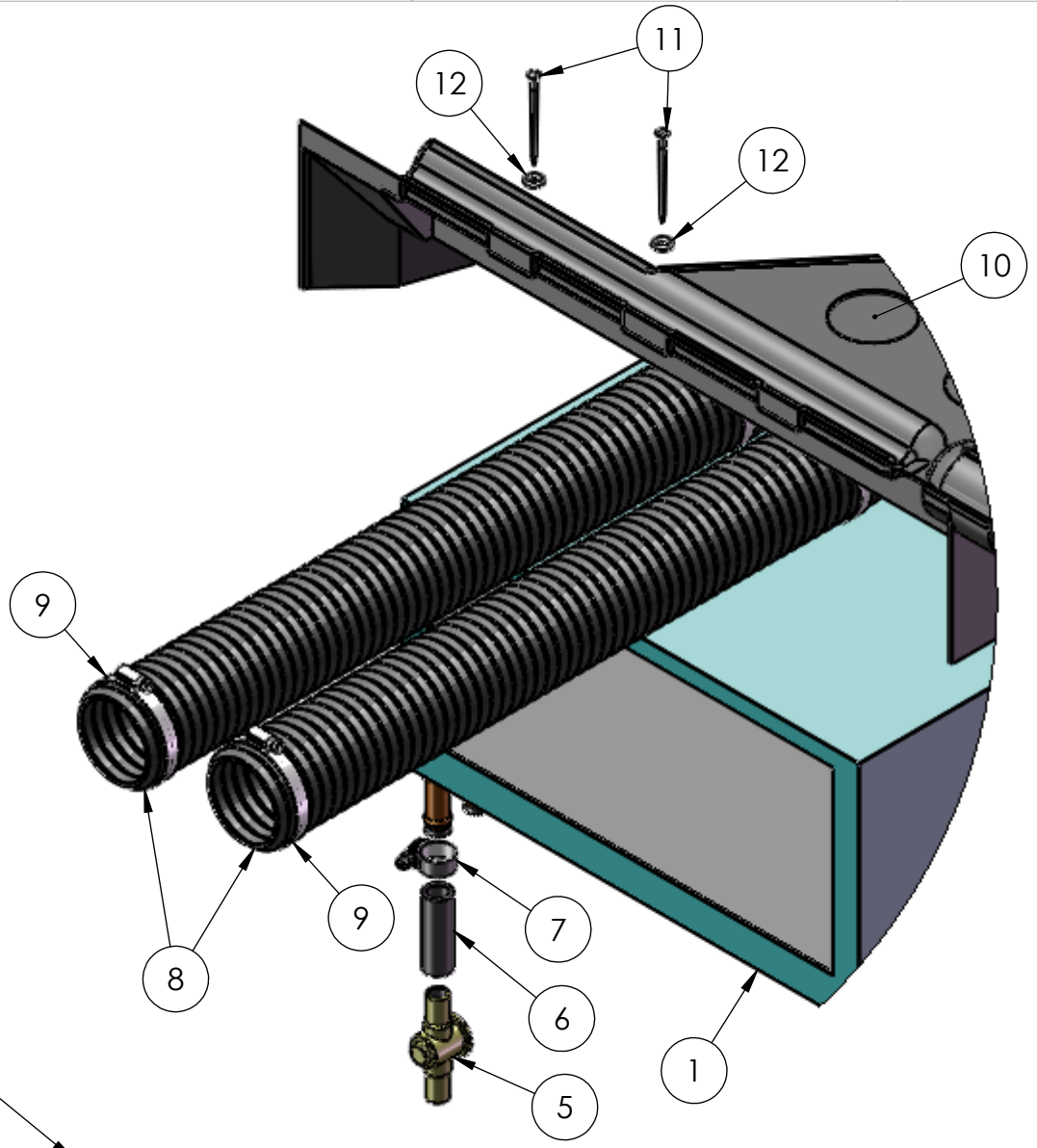

**DETAIL C
SCALE 1 : 5**

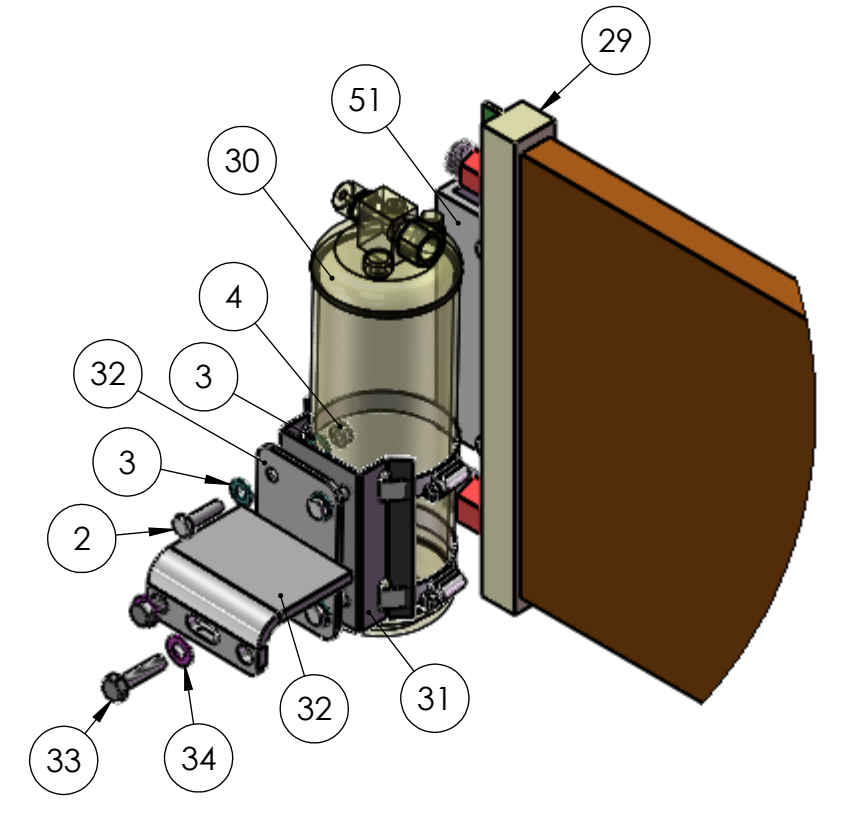

**DETAIL B
SCALE 1 : 4**

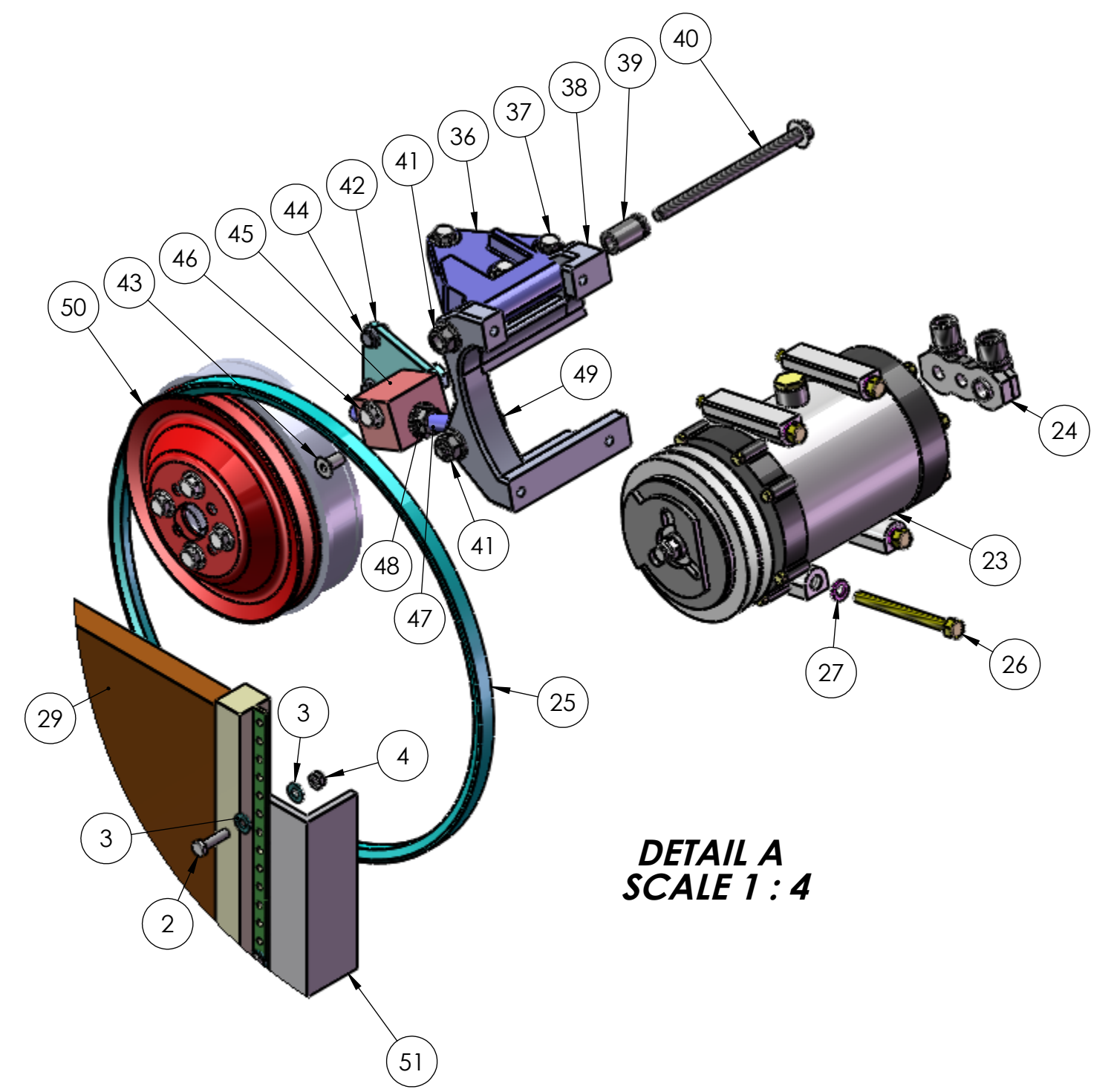
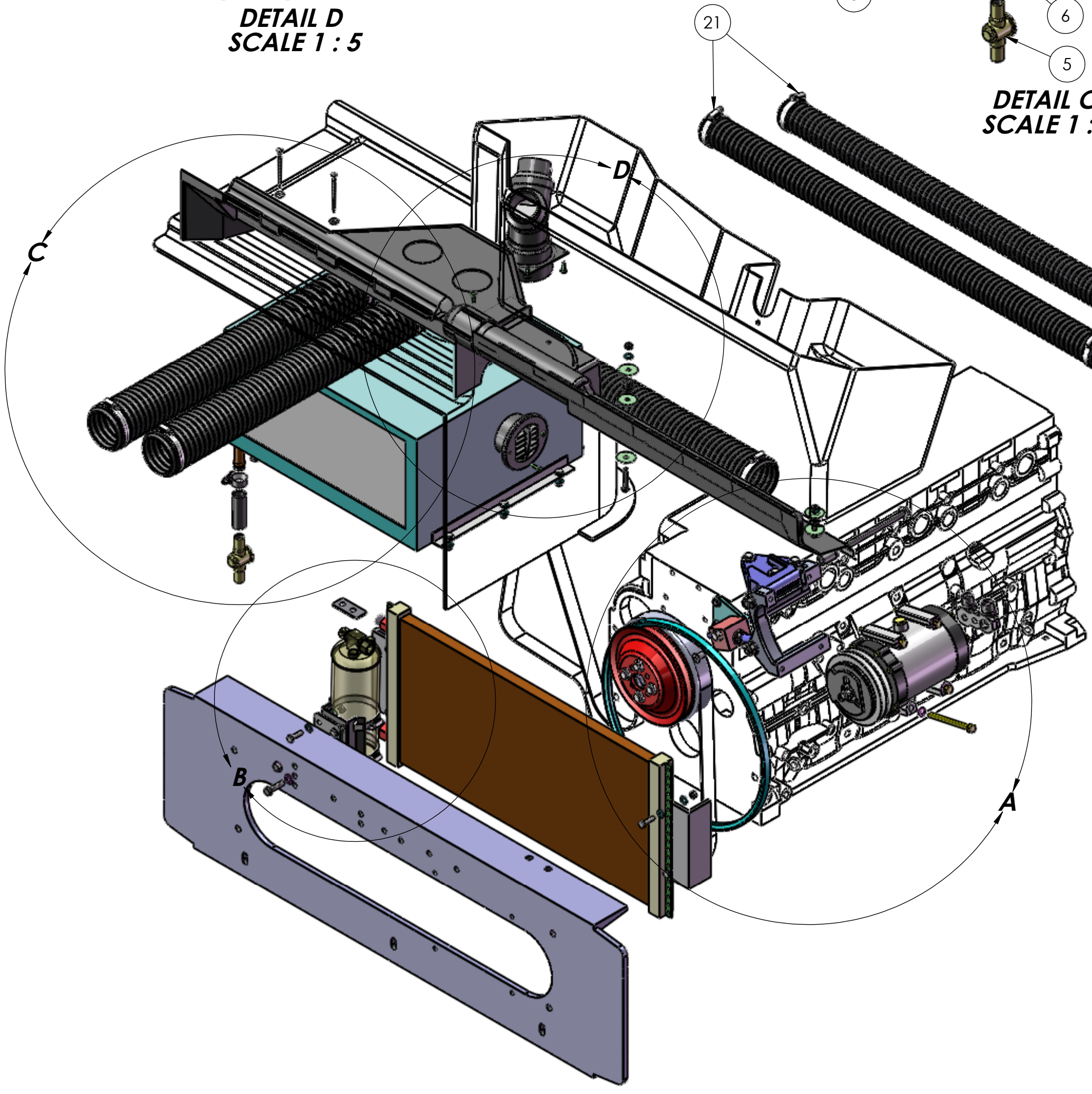

**DETAIL A
SCALE 1 : 4**

DIMENSIONS ARE IN INCHES
TOLERANCES:
DECIMAL:
X.X ± 0.06
X.XX ± 0.03
X.XXX ± 0.005
ANGULAR: ± 0.5°
FRACTIONAL: ± 1/32"

INTERPRET GEOMETRIC TOLERANCING PER: ASME 14.5M-1994

MATERIAL

FINISH

THICKNESS

NAME	DATE
DRAWN MJW	11/12/12
CHECKED	
APPROVED	

DO NOT SCALE DRAWING

THE SUBJECT MATTER SHOWN AND DESCRIBED IN THIS DRAWING AND ANY OTHER INFORMATION ADVANCED IN CONNECTION THEREWITH IS PROPRIETARY PROPERTY AND IS TO BE HELD IN STRICT CONFIDENCE BY YOU. ALL RIGHTS TO ANY INVENTIONS, DESIGNS, TRADE MARKS, TRADE NAMES AND COPYRIGHTS DISCLOSED ARE RESERVED TO TICO TERMINAL SERVICES, INC.

TICO/Terminal Service 66 CYPRESS RIDGE DR. RIDGELAND, SC 29936 (843) 717-2226	
TITLE: HEATER-A/C ASSY QSB	
SIZE C	DWG. NO. 71538-B1
REV B1	SHEET 1 OF 1

TICO PRO-SPOTTER

S/N:		HEATER-A/C ASSY ISB		71538
ITEM	PART #	QTY/M	DESCRIPTION	TASK
	71538-B1	REF	HEATER - A/C ASSY ISB	
1	90694	1	HEATER - A/C	
2	82370	6	BOLT, HEX, 1/4-20 X 1" LG	
3	85089	12	WASHER, 1/4"	
4	85023	6	NUT, NYLOCK, 1/4-20	
5	90694-5	1	VALVE, HEATER	
6	90694-6	1	HOSE, HEATER, 5/8"x 2"	
7	24111	1	CLAMP HOSE	
8	90694-4	3	DUCT, 3" FLEX X 2' LG	
9	24120	6	CLAMP, HOSE, 3"	
10	90845	1	MANIFOLD DEFROSTER, LEFT	
11	80272	2	SCREW, WOOD, # 10 X 3 LG	
12	80302	2	WASHER, FINISHING, # 10	
13	80262	1	SCREW, WOOD, 5-20 X 3/4 LG	
14	90846	1	MANIFOLD DEFROSTER, RIGHT	
15	82392	2	BOLT, HEX, 1/4-20 X 1 1/2 LG	
16	80129	6	WASHER, FENDER, 1/4 X 1 1/4 OD	
17	80303	2	GROMMET, RUBBER, 1/2 X 5/8 X 5/16 HOLE	
18	90857	1	"Y" CONNECTOR, 3" X 2" X 2"	
19	90694-2	1	HOSE, ADAPTER, 3"	
20	90694-3	2	DUCT, 2" FLEX X 3' LG	
21	24117	4	CLAMP, HOSE, 2"	
22	90874	1	VENT, LOUVER, HEAT	
23	91603	1	COMPRESSOR, A/C	
24	60833	1	MANIFOLD	
25	42058	1	BELT, VEE, 44 3/4	
26	80343	4	BOLT, 8 MM X 1.25 x 95 MM LG	
27	85135	4	LOCKWASHER, 3/8	
28	12338	1	BRACKET, A/C HOSE CLIP	
29	60834	1	CONDENSER	
30	40643	1	RECEIVER, DRIER	
31	40644	1	BRACKET, RECEIVER, DRIER	
32	20104	2	BRACKET, MOUNT	
33	82382	2	BOLT, HEX, 5/16-18 X 1 1/4 LG	
34	85112	4	LOCKWASHER, 5/16	
35	85024	4	LOCKNUT, NYLOK, 5/16-18	
REV	DATE	BY		SHEET
				1 of 2

