

DETAIL A
SCALE 1 : 2

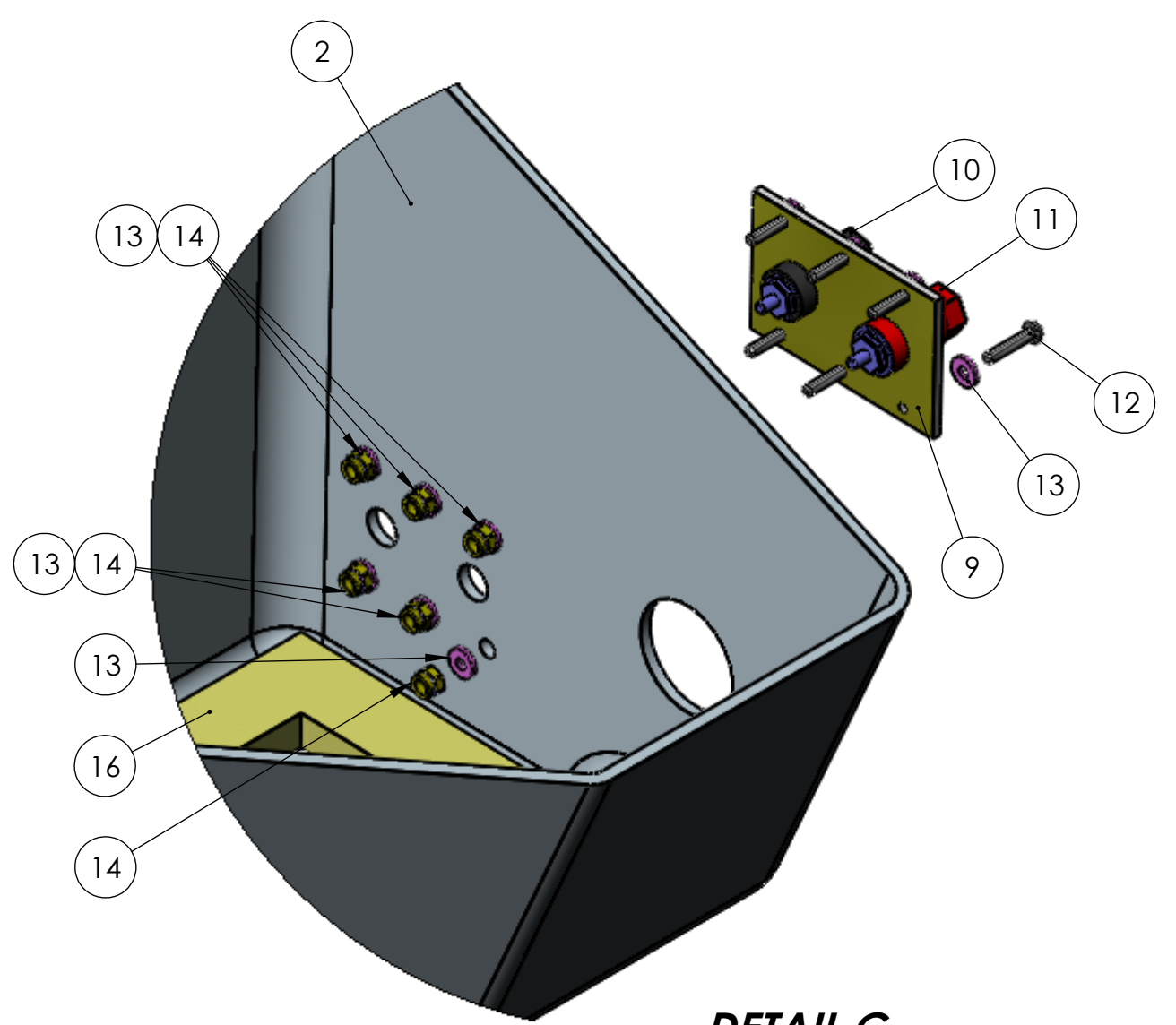

DETAIL C
SCALE 1 : 2

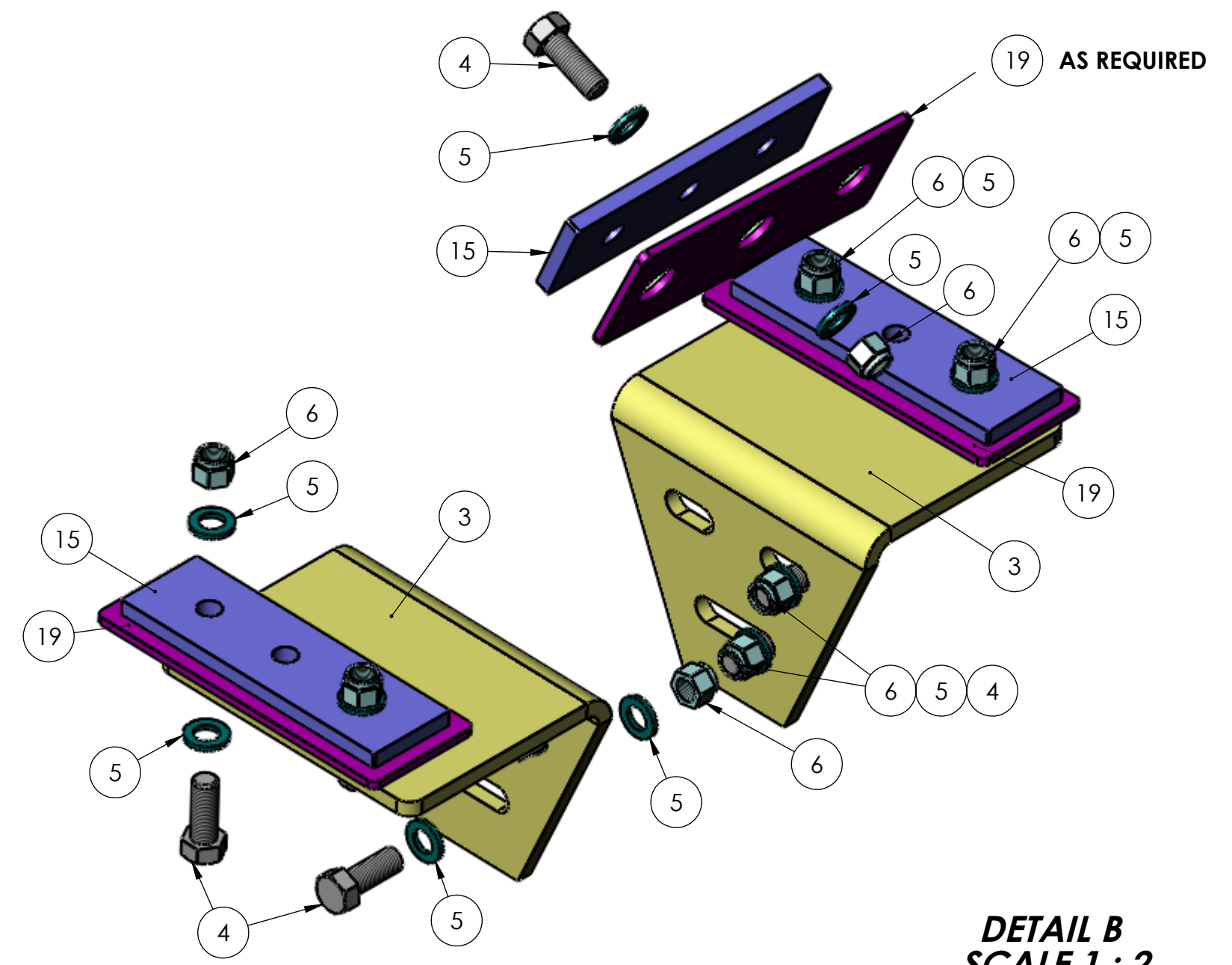

DETAIL B
SCALE 1 : 2

DIMENSIONS ARE IN INCHES		NAME	DATE	TICO/TERMINAL SERVICE 66 CYPRESS RIDGE DR. RIDGELAND, SC 29936 (843) 717-2226	
TOLERANCES:		DRAWN	RWC		7/8/11
DECIMAL:		CHECKED			
X.X ± 0.1250		APPROVED		TITLE:	
X.XX ± 0.0625				FLOOR ASSY - DASH	
X.XXX ± 0.0313				SIZE DWG. NO. REV	
ANGULAR: ± 1°				C 71551-E1 A	
FRACTIONAL: ± 1/16"		DO NOT SCALE DRAWING		SCALE: 1:12 WEIGHT: 739.36 SHEET 1 OF 1	
INTERPRET GEOMETRIC TOLERANCING PER: ASME 14.5M-1994		THE SUBJECT MATTER SHOWN AND DESCRIBED IN THIS DRAWING AND ANY OTHER INFORMATION ADVANCED IN CONNECTION THEREWITH IS PROPRIETARY PROPERTY AND IS TO BE HELD IN STRICT CONFIDENCE BY YOU. ALL RIGHTS TO ANY INVENTIONS, DESIGNS, TRADE MARKS, TRADE NAMES AND COPYRIGHTS DISCLOSED ARE RESERVED TO TICO TERMINAL SERVICES, INC.			
MATERIAL					
FINISH					
THICKNESS					