

8 7 6 5 4 3 2 1

D

D

C

C

B

B

A

A

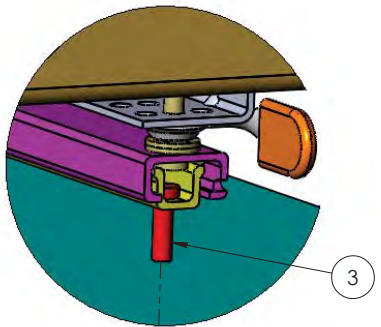

**DETAIL B**  
SCALE 1 : 2

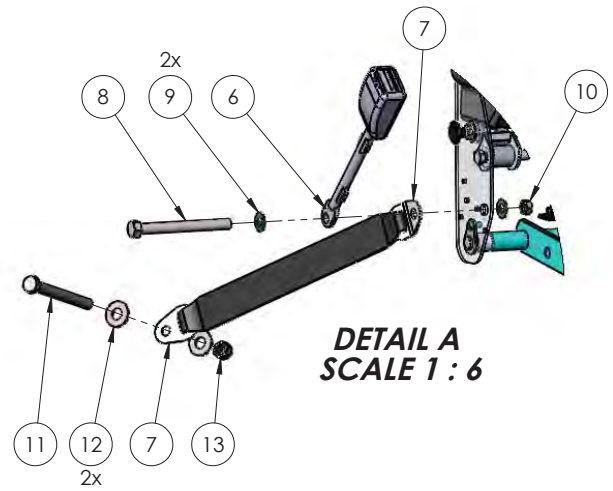
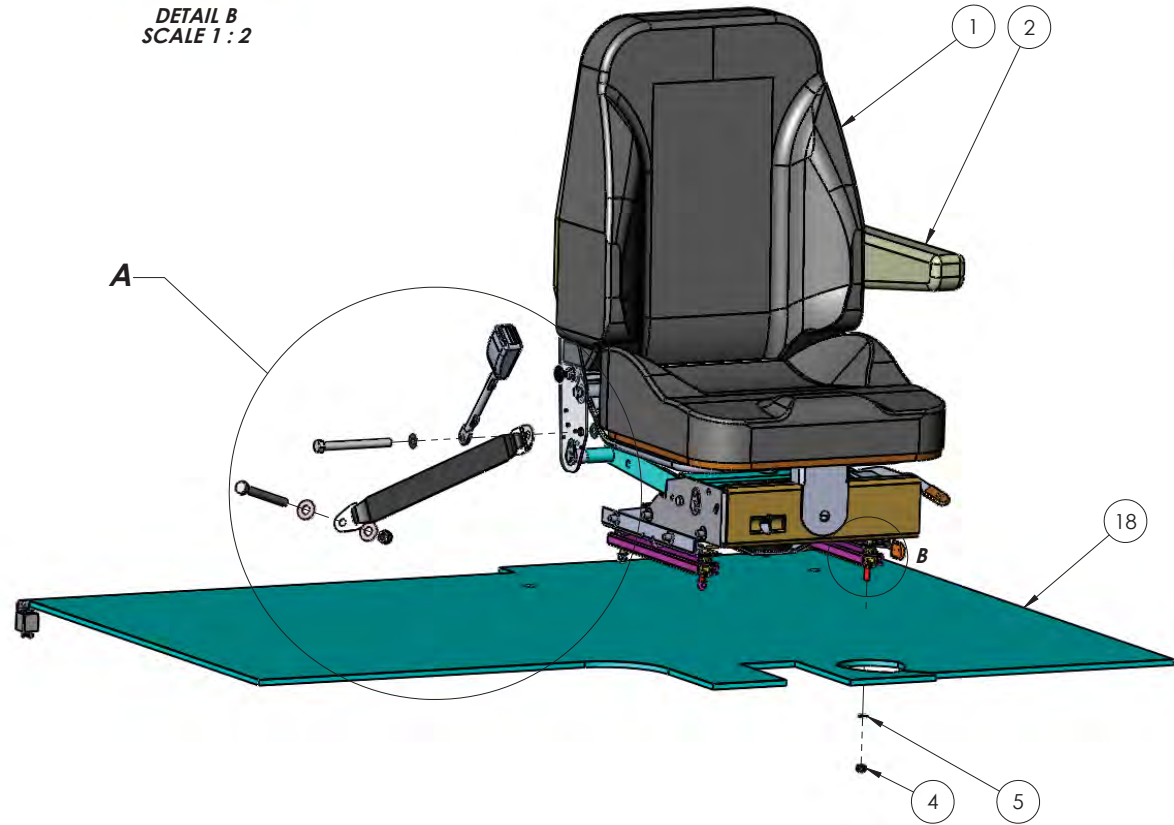
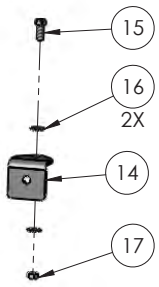

**DETAIL A**  
SCALE 1 : 6

DIMENSIONS ARE IN INCHES  
TOLERANCES:  
DECIMAL:  
X.X ± 0.06  
X.XX ± 0.03  
X.XXX ± 0.005  
ANGULAR: ± 0.5°  
FRACTIONAL: ± 1/32"

INTERPRET GEOMETRIC TOLERANCING PER: ASME 14.5M-1994  
MATERIAL  
FINISH  
THICKNESS

NAME  
DATE  
DRAWN LP 09/04/12  
REVISED DFM 4/4/2016  
APPROVED  
DO NOT SCALE DRAWING

THE SUBJECT MATTER SHOWN AND DESCRIBED IN THIS DRAWING AND ANY OTHER INFORMATION ADVANCED IN CONNECTION THEREWITH, IS PROPRIETARY PROPERTY AND IS TO BE HELD IN STRICT CONFIDENCE BY YOU. ALL RIGHTS TO ANY INVENTIONS, DESIGNS, TRADE MARKS, TRADE NAMES AND COPYRIGHTS DISCLOSED ARE RESERVED TO TICO TERMINAL SERVICES, INC.

TICO  
TICO/TERMINAL SERVICE  
66 CYPRESS RIDGE DR.  
RIDGELAND, SC 29936  
(843) 717-2226

TITLE:  
**SEAT, MID BACK**

SIZE DWG. NO.  
**B** 71472-B1

SCALE: 1:8 WEIGHT: 358.06 SHEET 1 OF 1

8 7 6 5 4 3 2 1

