

**DETAIL A  
SCALE 1 : 4**

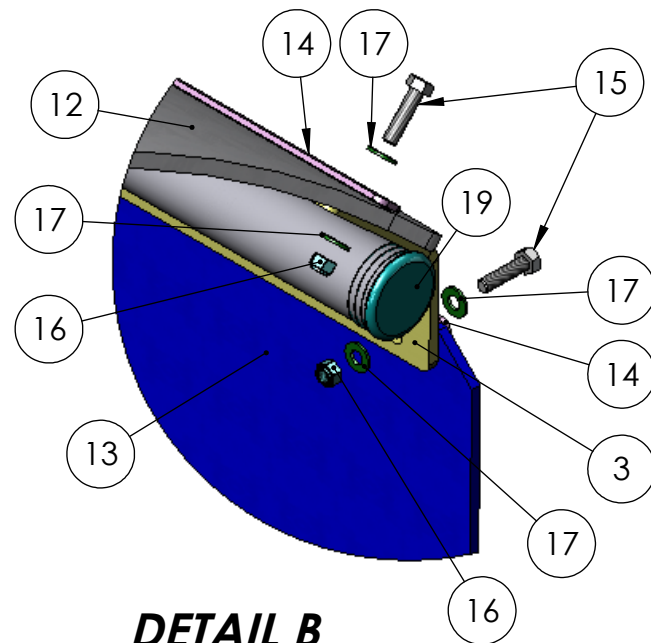

**DETAIL B  
SCALE 1 : 4**

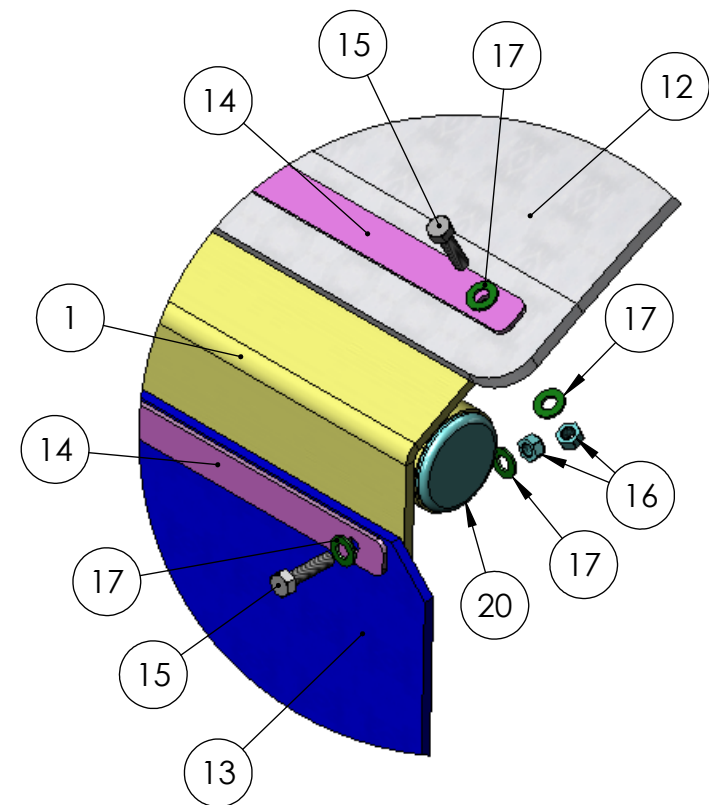

**DETAIL C  
SCALE 1 : 4**

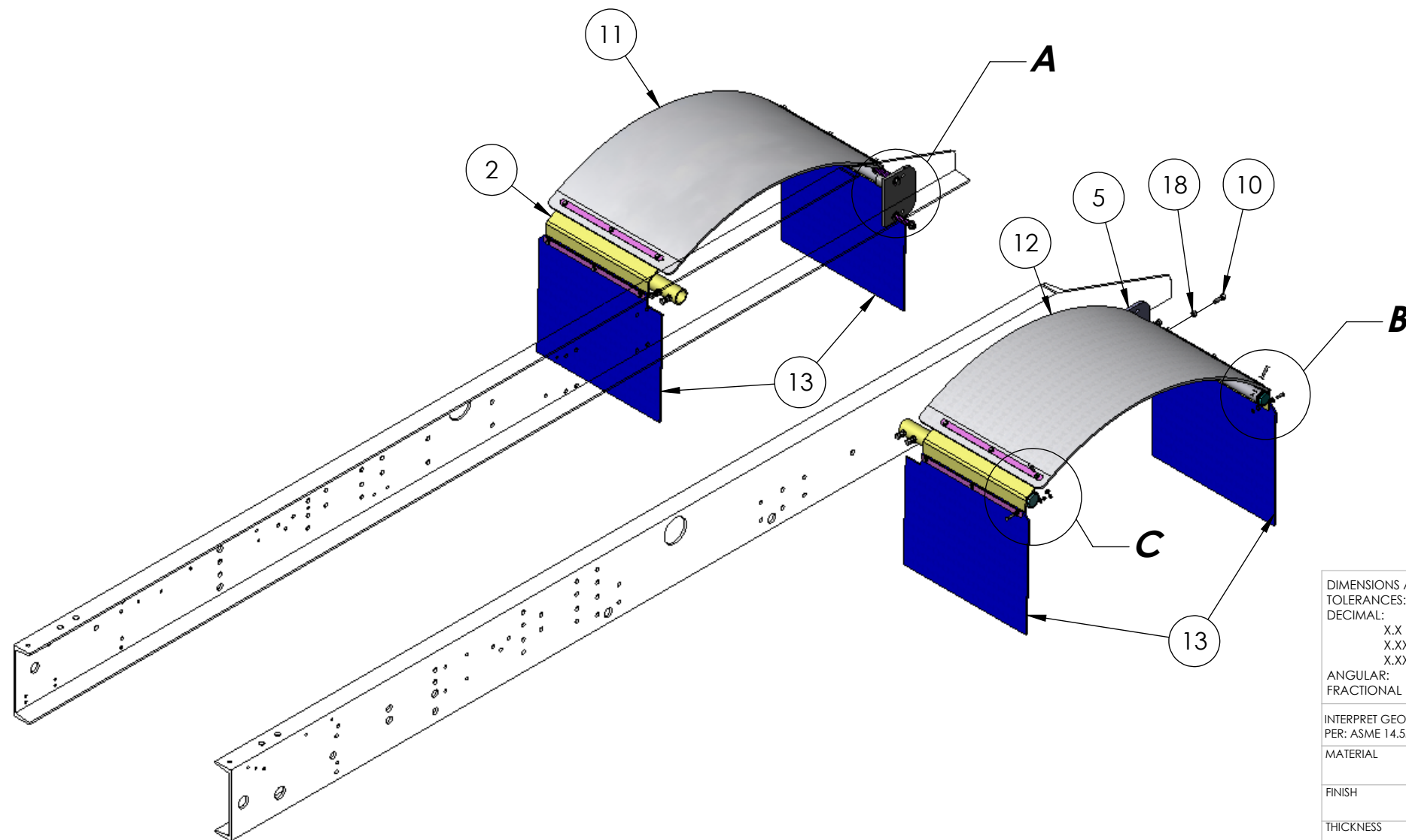

DIMENSIONS ARE IN INCHES TOLERANCES: DECIMAL: X.X ± 0.06 X.XX ± 0.03 X.XXX ± 0.005 ANGULAR: ± 0.5° FRACTIONAL ± 1/32"		DRAWN	NAME	DATE	 TICO/TERMINAL SERVICE 66 CYPRESS RIDGE DR. RIDGELAND, SC 29936 (843) 717-2226
INTERPRET GEOMETRIC TOLERANCING PER: ASME 14.5M-1994		CHECKED	RWC	1/16/12	
MATERIAL		APPROVED			
FINISH		DO NOT SCALE DRAWING			TITLE: <b>FENDER-REAR</b>
THICKNESS		THE SUBJECT MATTER SHOWN AND DESCRIBED IN THIS DRAWING AND ANY OTHER INFORMATION ADVANCED IN CONNECTION THEREWITH, IS PROPRIETARY PROPERTY AND IS TO BE HELD IN STRICT CONFIDENCE BY YOU. ALL RIGHTS TO ANY INVENTIONS, DESIGNS, TRADE MARKS, TRADE NAMES AND COPYRIGHTS DISCLOSED ARE RESERVED TO TICO TERMINAL SERVICES, INC.			SIZE <b>B</b> DWG. NO. <b>71445-A1</b> REV <b>A1</b>
SCALE: 1:20			SHEET 1 OF 1		

