

**DETAIL A  
SCALE 1 : 4**

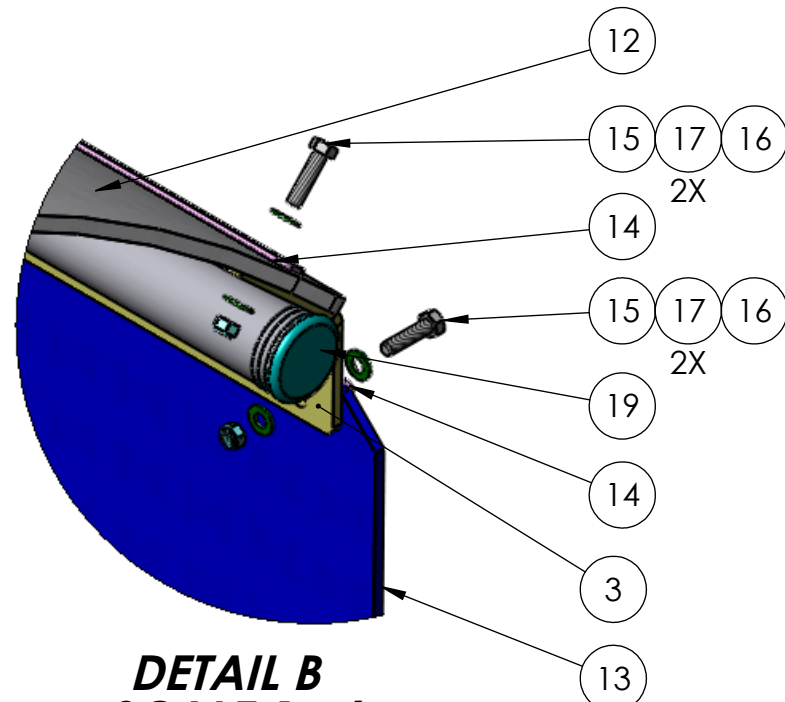

**DETAIL B  
SCALE 1 : 4**

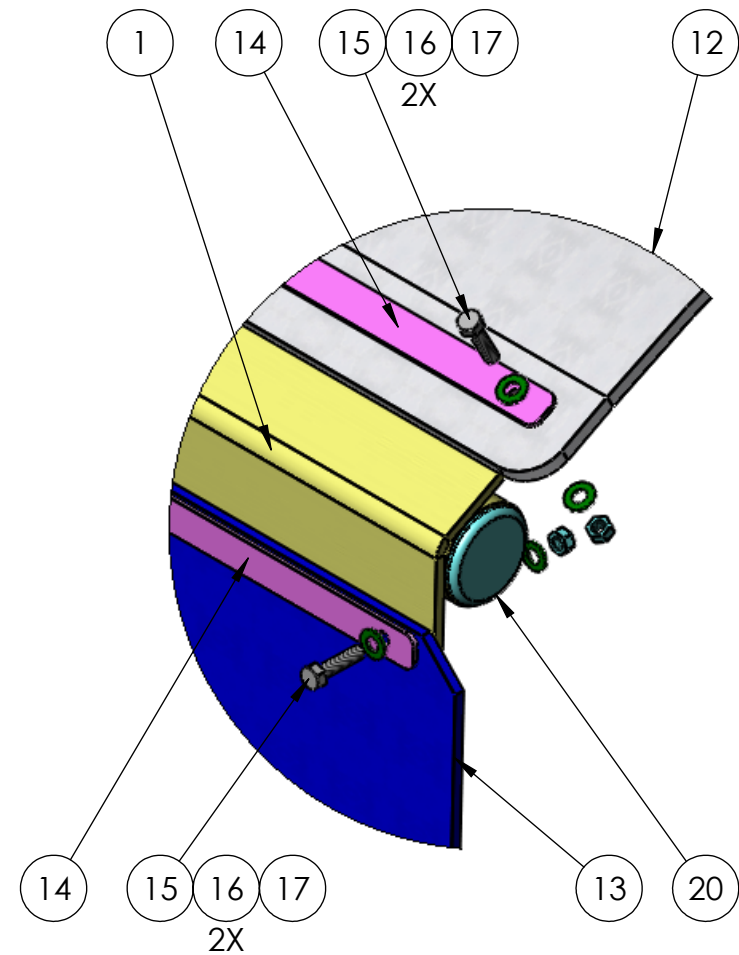

**DETAIL C  
SCALE 1 : 4**

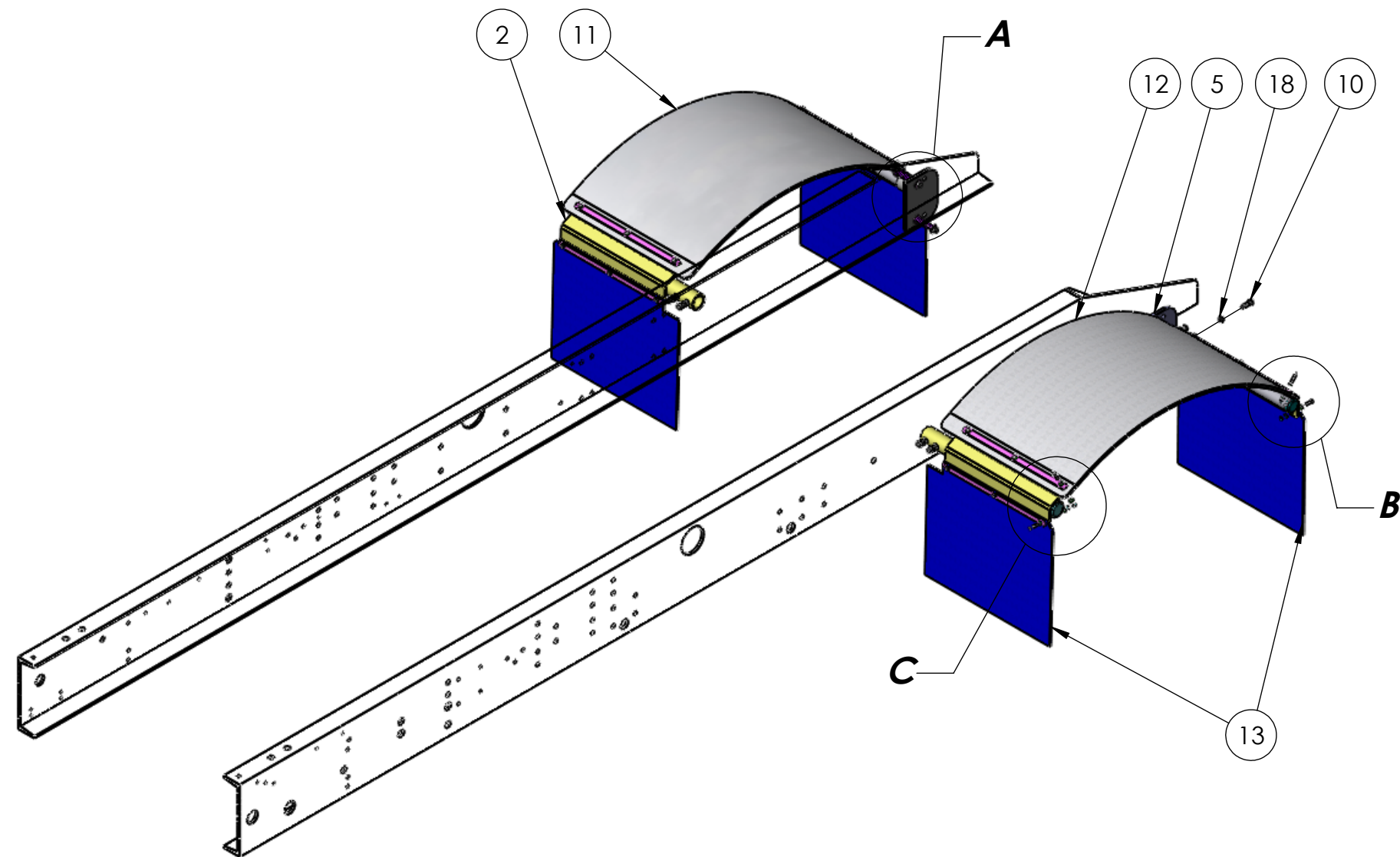

DIMENSIONS ARE IN INCHES TOLERANCES: DECIMAL: X.X ± 0.06 X.XX ± 0.03 X.XXX ± 0.005 ANGULAR: ± 0.5° FRACTIONAL ± 1/32"	DRAWN RWC	NAME RWC	DATE 1/16/12	 TICO/TERMINAL SERVICE 66 CYPRESS RIDGE DR. RIDGELAND, SC 29936 (843) 717-2226	
	REVISED DFM	DATE 3/25/2016	TITLE: FENDER, REAR WITH FLAPS		
	APPROVED	DO NOT SCALE DRAWING			SIZE <b>B</b>
	INTERPRET GEOMETRIC TOLERANCING PER: ASME 14.5M-1994	THE SUBJECT MATTER SHOWN AND DESCRIBED IN THIS DRAWING AND ANY OTHER INFORMATION ADVANCED IN CONNECTION THEREWITH, IS PROPRIETARY PROPERTY AND IS TO BE HELD IN STRICT CONFIDENCE BY YOU. ALL RIGHTS TO ANY INVENTIONS, DESIGNS, TRADE MARKS, TRADE NAMES AND COPYRIGHTS DISCLOSED ARE RESERVED TO TICO TERMINAL SERVICES, INC.			DWG. NO. 71445-E
MATERIAL	SCALE: 1:20		REV	SHEET 1 OF 1	
FINISH					
THICKNESS					

