

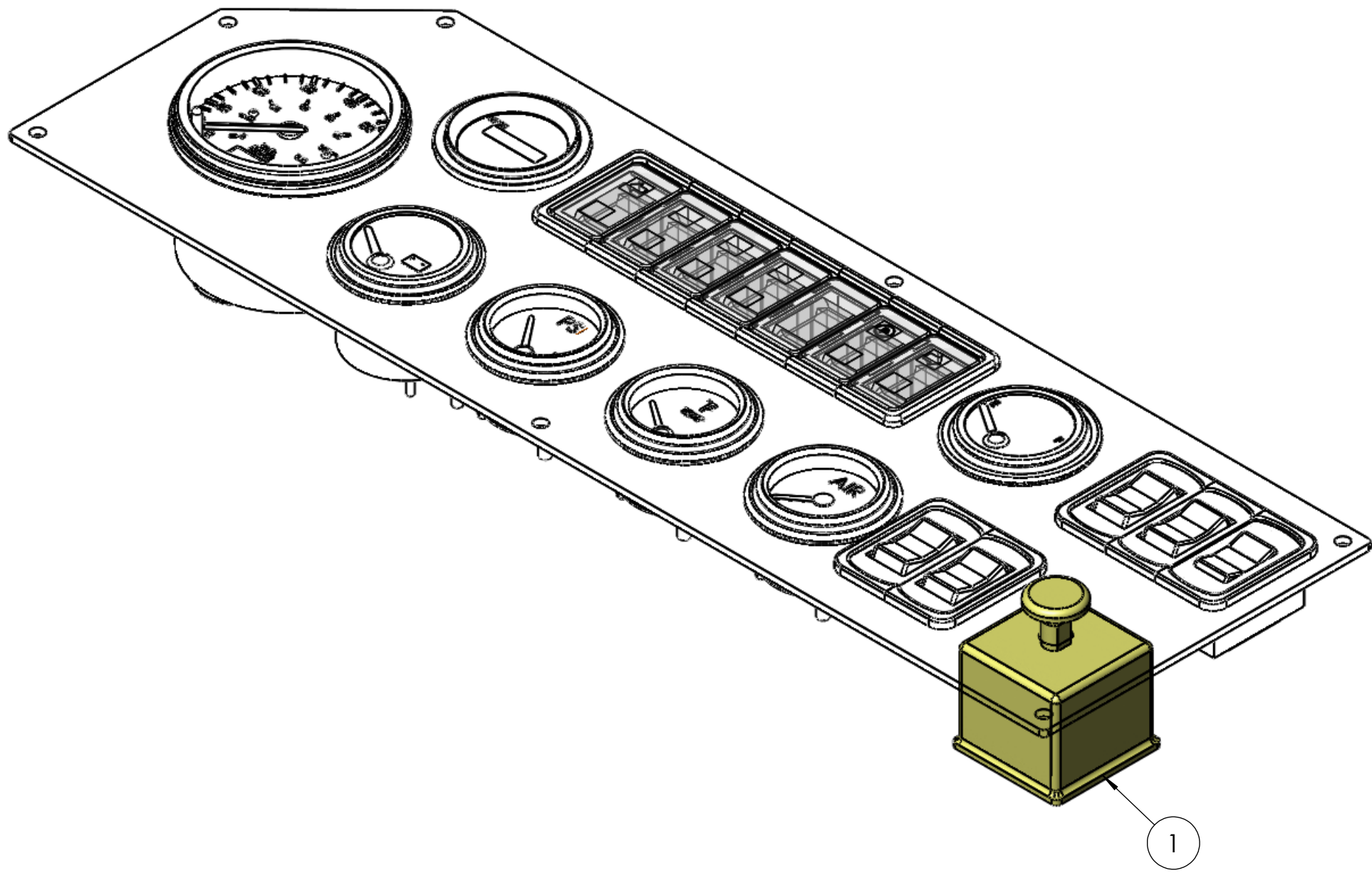

8 7 6 5 4 3 2 1

D
C
B
A

D
C
B
A



DIMENSIONS ARE IN INCHES TOLERANCES: DECIMAL: X.X ± 0.06 X.XX ± 0.03 X.XXX ± 0.005 ANGULAR: ± 0.5° FRACTIONAL ± 1/32"		NAME SMB	DATE 8/29/14	 TICO/TERMINAL SERVICE 66 CYPRESS RIDGE DR. RIDGELAND, SC 29936 (843) 717-2226	
INTERPRET GEOMETRIC TOLERANCING PER: ASME 14.5M-1994		CHECKED	APPROVED		TITLE: INSTALLATION, INTERMITTENT WIPERS
MATERIAL		DO NOT SCALE DRAWING			SIZE B
FINISH		THE SUBJECT MATTER SHOWN AND DESCRIBED IN THIS DRAWING AND ANY OTHER INFORMATION ADVANCED IN CONNECTION THEREWITH, IS PROPRIETARY PROPERTY AND IS TO BE HELD IN STRICT CONFIDENCE BY YOU. ALL RIGHTS TO ANY INVENTIONS, DESIGNS, TRADE MARKS, TRADE NAMES AND COPYRIGHTS DISCLOSED ARE RESERVED TO TICO TERMINAL SERVICES, INC.		DWG. NO. 71388-C1	REV
THICKNESS		SCALE: 1:5		WEIGHT: 7.85	SHEET 1 OF 1

8 7 6 5 4 3 2 1

