

DETAIL B
SCALE 1 : 4

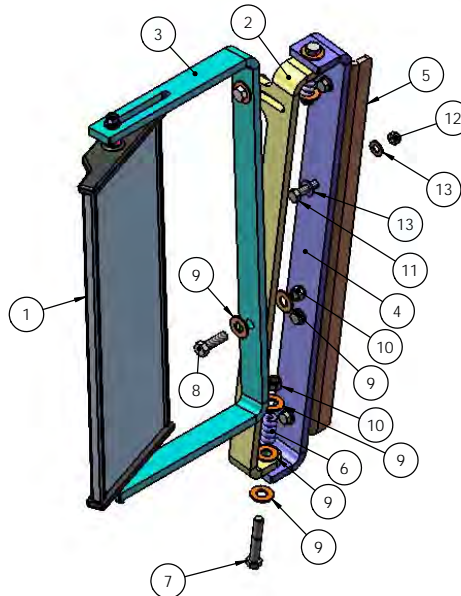

DETAIL A
SCALE 1 : 4

DIMENSIONS ARE IN INCHES		NAME	DATE	 TICO/TERMINAL SERVICE 66 CYPRESS RIDGE DR. RIDGELAND, SC 29936 (843) 717-2226
TOLERANCES:		DRAWN	RWC	
DECIMAL:		CHECKED		
.XX ± 0.1250 .XXX ± 0.0625 .XXXX ± 0.0313 ANGULAR ± 1° FRACTIONAL ± 1/16"		APPROVED		
INTERPRET GEOMETRIC TOLERANCING PER: ASME Y14.5M-1994		DO NOT SCALE DRAWING		TITLE:
MATERIAL		THE SUBJECT MATTER SHOWN AND DESCRIBED IN THIS DRAWING AND ANY OTHER INFORMATION ADVANCED IN CONNECTION THEREWITH IS PROPRIETARY PROPERTY AND IS TO BE HELD IN STRICT CONFIDENCE BY YOU. ALL RIGHTS TO ANY INVENTIONS, DESIGNS, TRADE MARKS, TRADE NAMES AND COPYRIGHTS DISCLOSED ARE RESERVED TO TICO TERMINAL SERVICES, INC.		
FINISH		SIZE	DWG. NO.	REV
THICKNESS		C	71245-C1	C1
		SCALE: 1:10	1	SHEET 1 OF 1

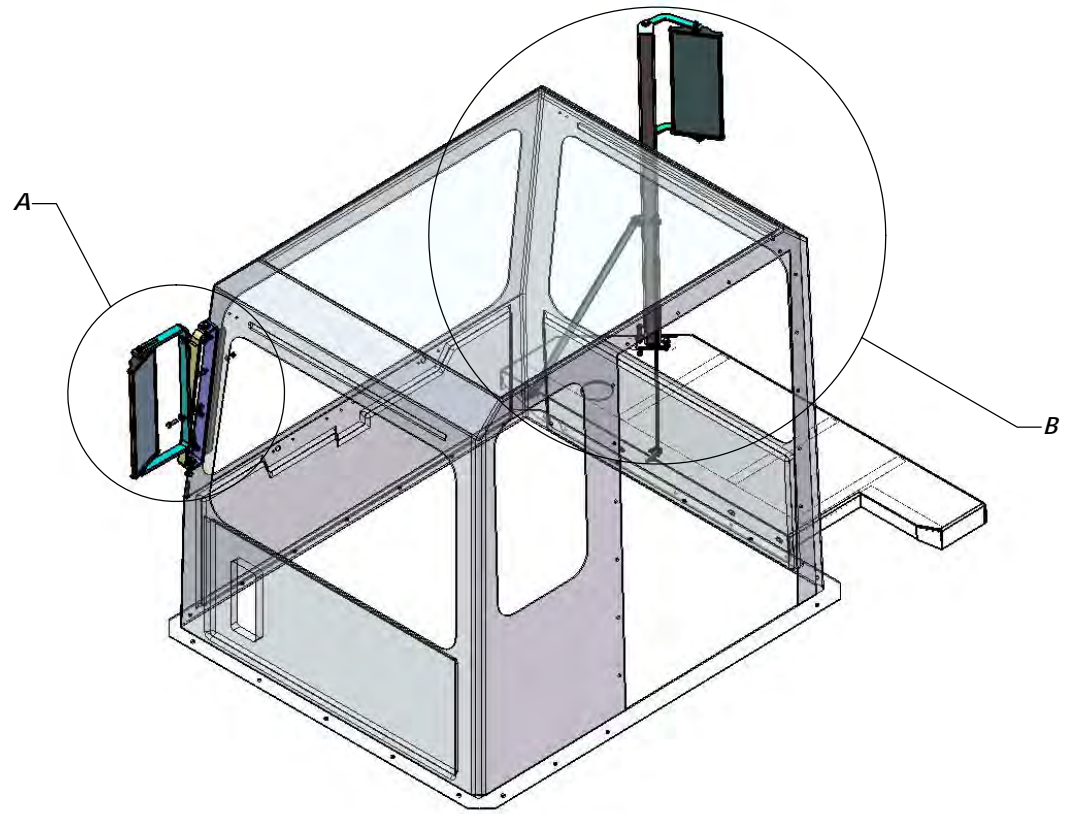