

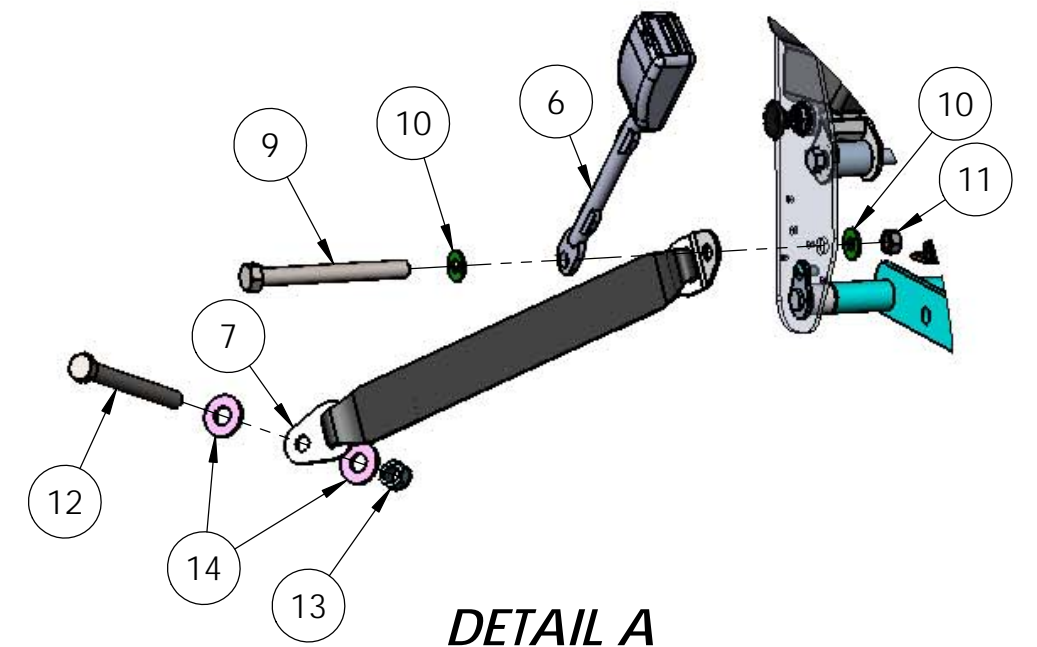

8 7 6 5 4 3 2 1

D
C
B
A

D
C
B
A

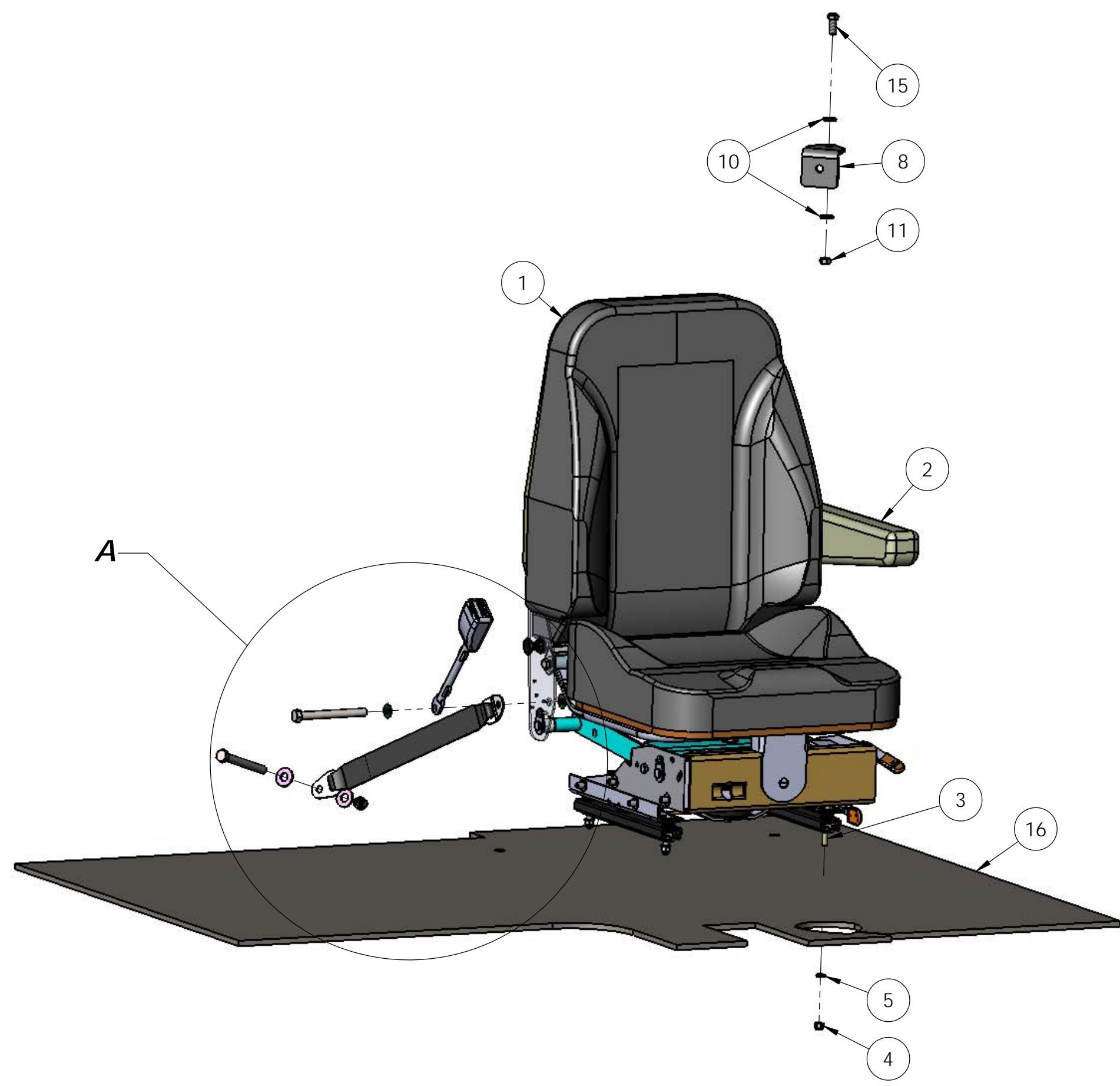

DETAIL A
SCALE 1 : 6

DIMENSIONS ARE IN INCHES TOLERANCES: DECIMAL: X.X ± 0.06 X.XX ± 0.03 X.XXX ± 0.005 ANGULAR: ± 0.5° FRACTIONAL ± 1/32"		NAME LP	DATE 09/04/12	 TICO/TERMINAL SERVICE 66 CYPRESS RIDGE DR. RIDGELAND, SC 29936 (843) 717-2226
INTERPRET GEOMETRIC TOLERANCING PER: ASME 14.5M-1994	THE SUBJECT MATTER SHOWN AND DESCRIBED IN THIS DRAWING AND ANY OTHER INFORMATION ADVANCED IN CONNECTION THEREWITH, IS PROPRIETARY PROPERTY AND IS TO BE HELD IN STRICT CONFIDENCE BY YOU. ALL RIGHTS TO ANY INVENTIONS, DESIGNS, TRADE MARKS, TRADE NAMES AND COPYRIGHTS DISCLOSED ARE RESERVED TO TICO TERMINAL SERVICES, INC.	TITLE: SEAT, AIR RIDE - MID BACK		
MATERIAL	SIZE B DWG. NO. 71042-B1 REV B1	SCALE: 1:8 WEIGHT: 358.01 SHEET 1 OF 1		
FINISH				
THICKNESS				

8 7 6 5 4 3 2 1

