

8 7 6 5 4 3 2 1

D
C
B
A

D
C
B
A

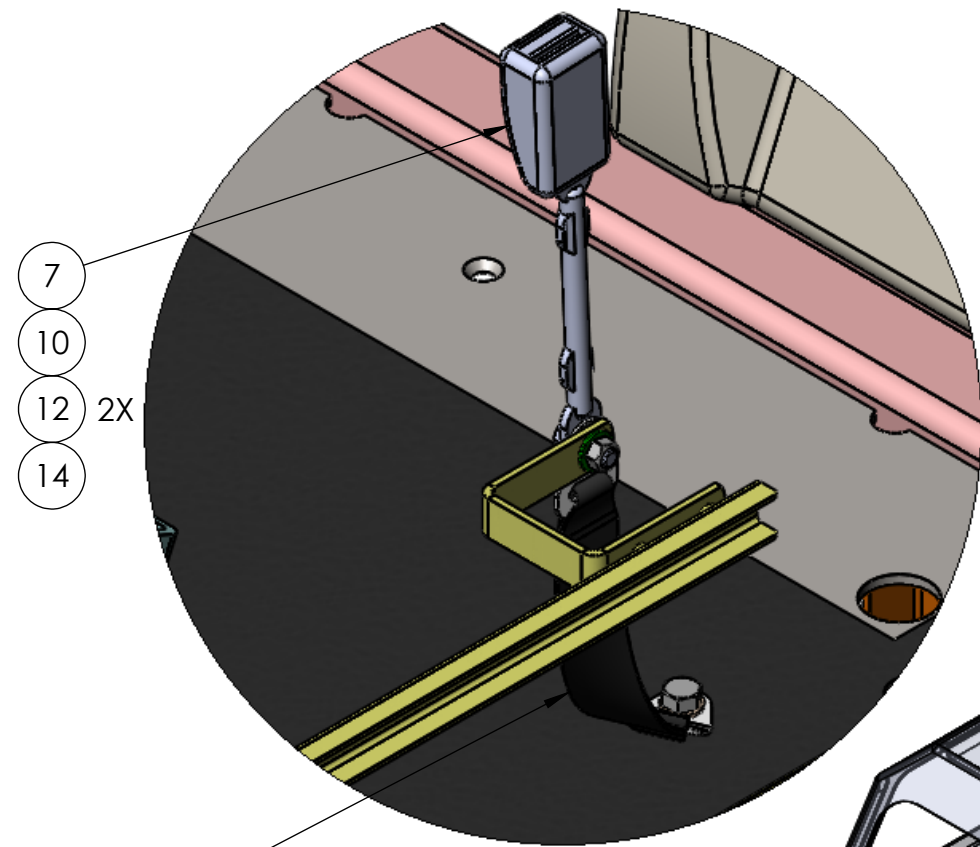

SEAT BELT & TETHER

- 8
- 9
- 11 2X
- 13

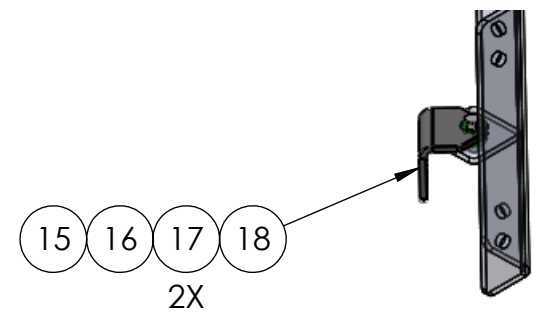

SHOULDER STRAP

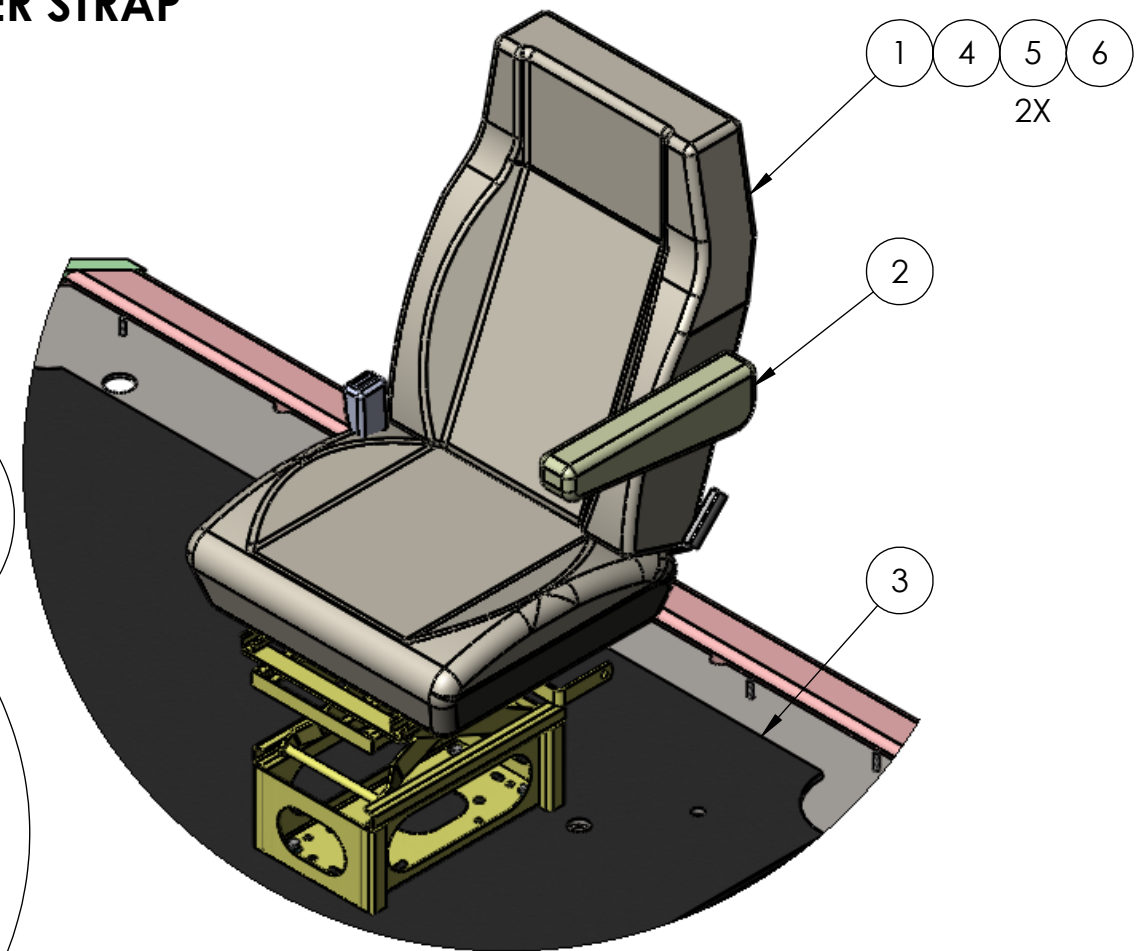
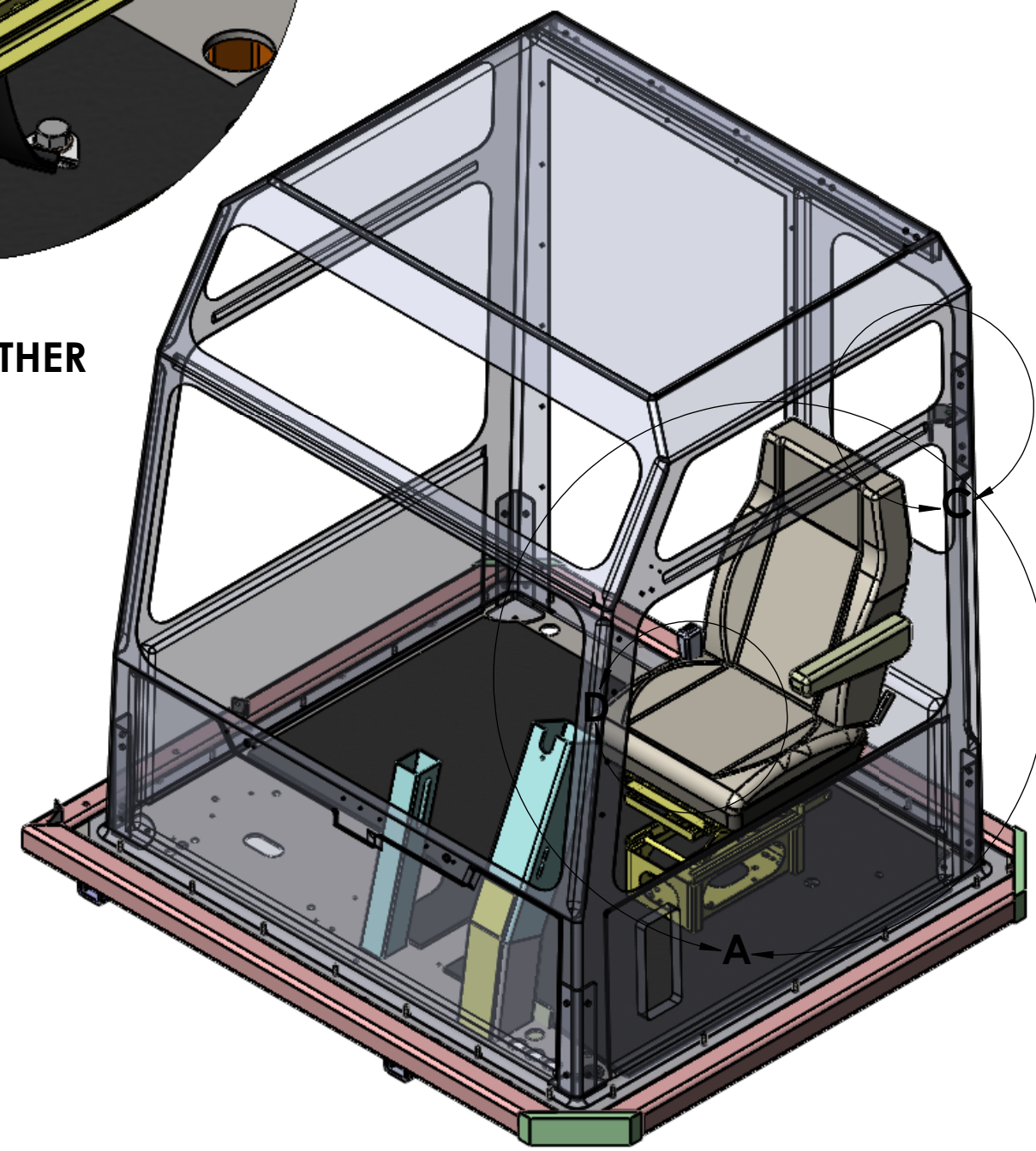

SEAT & FLOOR

DIMENSIONS ARE IN INCHES TOLERANCES: DECIMAL: X.X ± 0.06 X.XX ± 0.03 X.XXX ± 0.005 ANGULAR: ± 0.5° FRACTIONAL ± 1/32"		NAME MPC	DATE 03/22/2017	 TICO MANUFACTURING 66 CYPRESS RIDGE DR. RIDGELAND, SC 29936 (843) 717-2226
MATERIAL	FINISH	THICKNESS	DO NOT SCALE DRAWING	
THE SUBJECT MATTER SHOWN AND DESCRIBED IN THIS DRAWING AND ANY OTHER INFORMATION ADVANCED IN CONNECTION THEREWITH, IS PROPRIETARY PROPERTY AND IS TO BE HELD IN STRICT CONFIDENCE BY YOU. ALL RIGHTS TO ANY INVENTIONS, DESIGNS, TRADE MARKS, TRADE NAMES AND COPYRIGHTS DISCLOSED ARE RESERVED TO TICO TERMINAL SERVICES, INC.				TITLE: ASSEMBLY, SEAT, NATIONAL
SIZE B		DWG. NO. 71012-B1	REV	
SCALE: 1:32		WEIGHT: 1386.12	SHEET 1 OF 1	

8 7 6 5 4 3 2 1

