

DETAIL A
SCALE 1 : 3

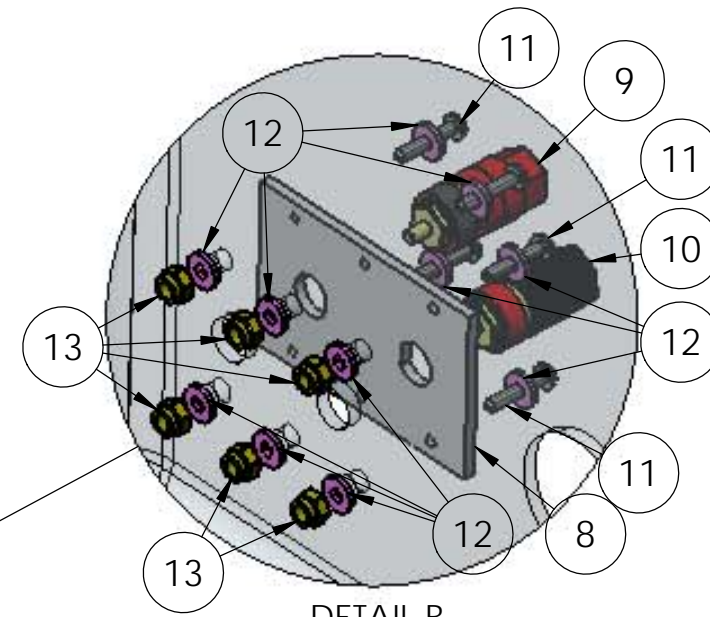

DETAIL B
SCALE 1 : 2

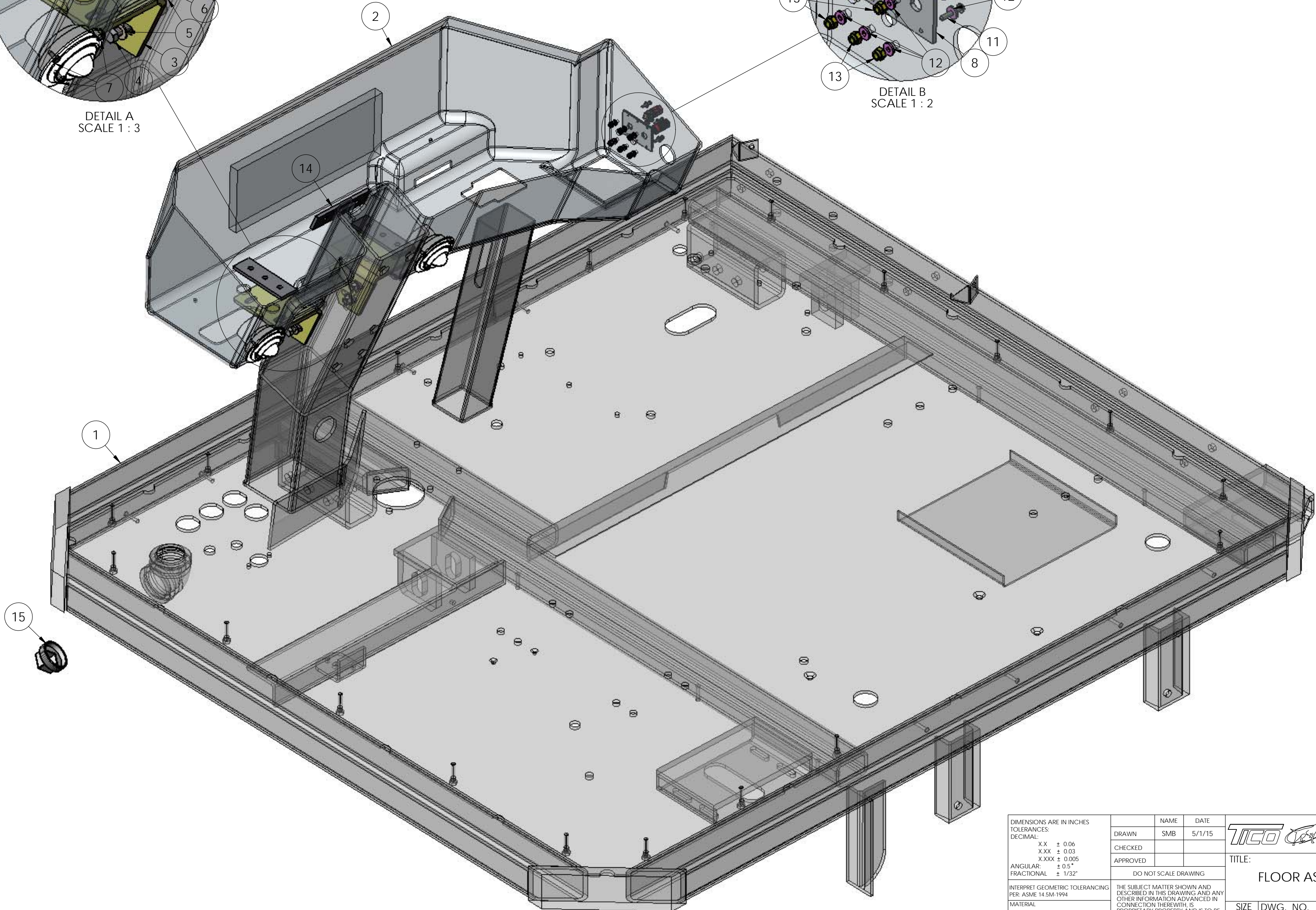

DIMENSIONS ARE IN INCHES	
TOLERANCES:	
DECIMAL:	
X.X ± 0.06	
X.XX ± 0.03	
X.XXX ± 0.005	
ANGULAR:	
± 0.5°	
FRACTIONAL:	± 1/32"
INTERPRET GEOMETRIC TOLERANCING PER: ASME 14.5M-1994	
MATERIAL:	
FINISH:	
THICKNESS:	

NAME	DATE
DRAWN SMB	5/1/15
CHECKED	
APPROVED	
DO NOT SCALE DRAWING	
THE SUBJECT MATTER SHOWN AND DESCRIBED IN THIS DRAWING AND ANY OTHER INFORMATION ADVANCED IN CONNECTION THEREWITH, IS PROPRIETARY PROPERTY AND IS TO BE HELD IN STRICT CONFIDENCE BY YOU. ALL RIGHTS TO ANY INVENTIONS, DESIGNS, TRADE MARKS, TRADE NAMES AND COPYRIGHTS DISCLOSED ARE RESERVED TO TICO TERMINAL SERVICES, INC.	

 TICO/TERMINAL SERVICE 66 CYPRESS RIDGE DR. RIDGELAND, SC 29936 (843) 717-2226	
TITLE: FLOOR ASSEMBLY, HIGH CAB	
SIZE C	DWG. NO. 71002-G1
SCALE: 1:20	WEIGHT: SHEET 1 OF 1

